

FORSTER PRODUCTS

310 E. LANARK AVE, LANARK, IL 61046 www.forsterproducts.com PHONE (815) 493-6360 FAX (815) 493-2371

CO-AX[®] CASE AND CARTRIDGE INSPECTOR INSTRUCTIONS

FIGURE A

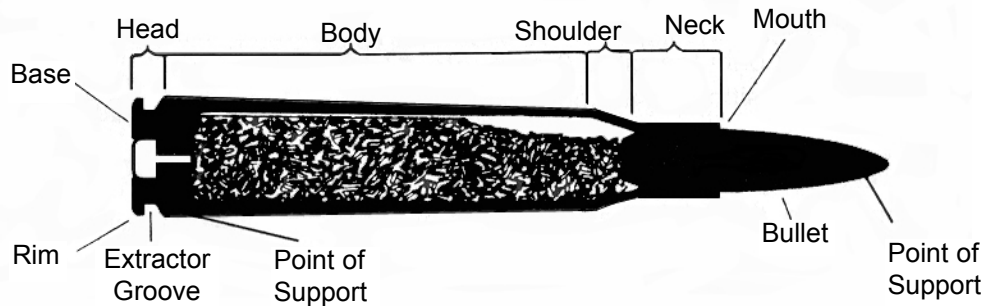

Improve your shooting accuracy by fine-tuning your cases and cartridges. Bench rest shooters, sharp shooters, varmint hunters and all types of marksmen, for that matter, expend effort to make their cartridge cases consistent. The Inspector will handle from .20 caliber to 45-70 cartridges. The Inspector is unique in that it supports the work in a manner which checks bullet and case alignment in relation to the centerline (axis) of the cartridge. This precision instrument makes three important measurements of cases and loaded ammo. The Co-Ax[®] Case Inspector measures these "accuracy-critical" dimensions: 1) Case neck wall thickness; 2) Case neck runout (concentricity); and 3) Bullet and cartridge runout of loaded rounds. Accuracy Checks 1 and 2 require the use of the proper-sized pilot that fits the inside diameter of the case neck closely.

To find which pilots are right for you, visit our online search database at www.forsterproducts.com. (Click on the "Parts Search" button in the top right navigation tabs.)

Variant readings received from the Inspector's Accuracy Checks 1 and 2 may suggest the need for you to size cases again or to outside neck turn. Unacceptable results from Accuracy Check 3 indicate the need to improve your bullet seating operation. Forster offers complete solutions for all these case and cartridge improvements.

FIGURE B

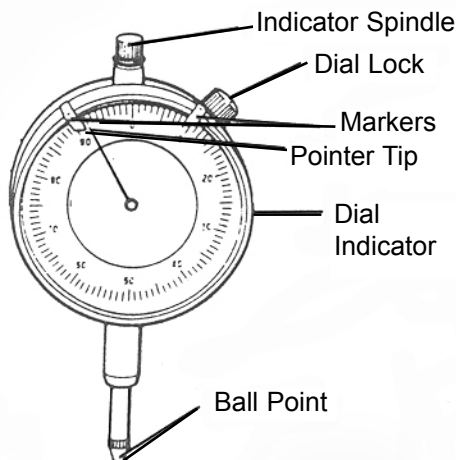
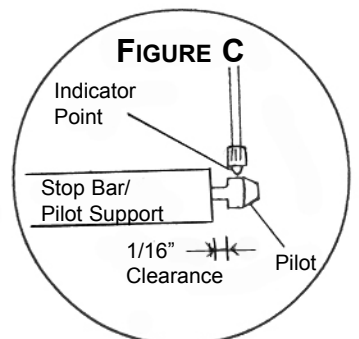
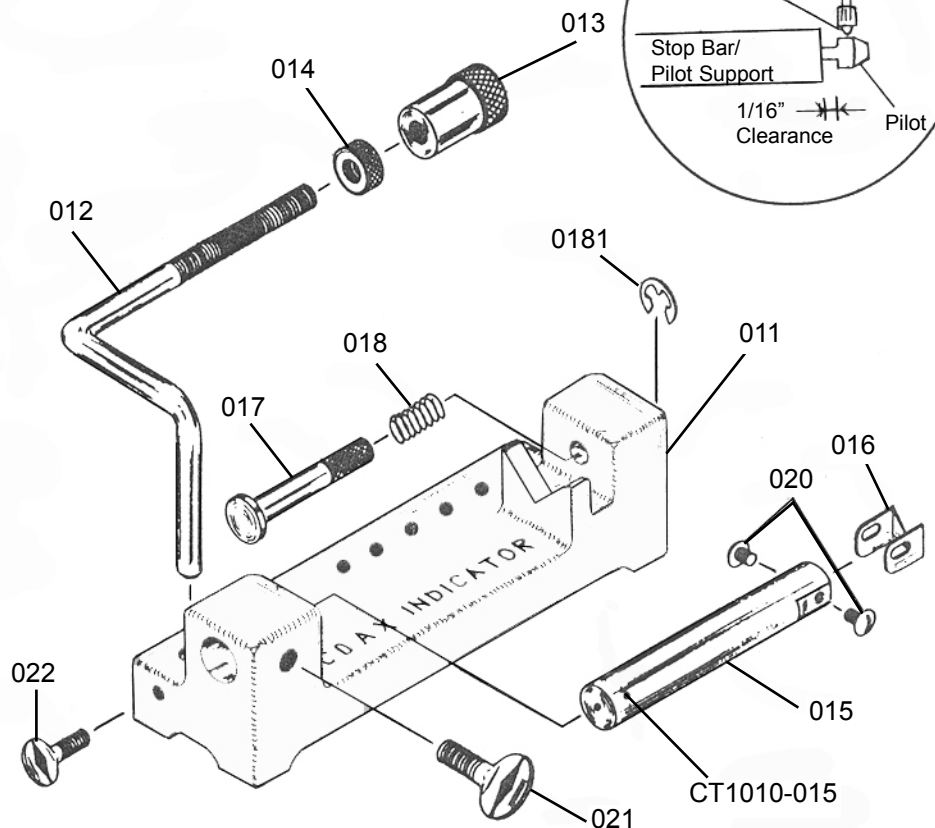

FIGURE C



| DESCRIPTION | PART # |
|------------------------|-------------|
| BASE | 010482-011 |
| BRACKET | 010482-012 |
| MAIN LOCK NUT | 010482-013 |
| KNURLED LOCK NUT | 010482-014 |
| STOP BAR/PILOT SUPPORT | 010482-015 |
| V-BRACKET | 010482-016 |
| V-BRACKET SCREWS (2) | 010482-020 |
| R.H. STOP PIN | 010482-017 |
| SPRING | 010482-018 |
| CLIP FOR STOP PIN | 010482-0181 |
| LARGE WING NUT | 010482-021 |
| SMALL WING NUT | 010482-022 |
| DIAL INDICATOR | 010482-028 |
| 8-32 SET SCREW | CT1010-015 |



DIAL INDICATOR (REFER TO FIGURE B)

This indicator is accurate to $\pm .001$ inches, and has a travel of $1/2$ ". The larger pointer reads from zero to .100 inches, the smaller pointer reads from zero to .500 inches.

The face of the outer dial may be turned to "zero out" the larger pointer. Simply loosen the dial lock on the indicator, then rotate the dial to align the zero mark with the pointer tip.

On the Inspector, the dial indicator is mounted to the bracket with two lock nuts. The bracket allows the indicator to be moved in a variety of positions for different-sized cases and cartridges.

CRITICAL ACCURACY CHECK 1 — CASE NECK WALL THICKNESS

Due to variations in case manufacturing, uneven neck walls do occur. The same uneven neck wall phenomenon occurs after brass has flowed unevenly after repeated firings. Cases should be cleaned first to ensure accurate readings. Use a cleaning brush to remove any powder residue from the inside diameter of the neck. Your Case Inspector provides a far more accurate check than that obtained with a dial caliper, which cannot properly measure round objects.

Select the proper pilot and fasten it in the stop bar/pilot support as per Figure C. The stop bar/pilot support should now have its pilot facing the V-block of the base. Adjust the stop bar/pilot support with adequate clearance for the case to be slipped on and off the pilot. The V-block on the red base does not have to be used for this inspection process. Lock the stop bar/pilot support in place with the large wing nut (#010482-021).

Adjust the dial indicator's point to read on the flat part of the pilot. It should rest on the pilot and be slightly compressed. Be sure that the ball point of the indicator is touching only the pilot. (See Photo 1.) Next, "zero out" the indicator. Simply loosen the dial lock located at the two o'clock position on the body of the indicator, then rotate the dial to line up the zero mark with the pointer tip.

Now you are ready to slip the case neck between the pilot and indicator to take a direct measurement of neck wall thickness. It is easiest to lift the ball point with one hand, then slide the case mouth onto the pilot and up against the stop bar/pilot support. Lower the ball point slowly into contact with the case. The reading on the dial is the thickness of the case neck at that point.

Use a Magic Marker to notate the point of your first reading, then take four or five more measurements around the case neck. If there is a variation of .0015" or greater, resize your cases and recheck the neck wall thickness. If resizing does not correct the variation, use a Forster Outside Neck Turner in conjunction with the Forster Case Trimmer.

CRITICAL ACCURACY CHECK 2 — CASE RUNOUT

This concentricity check is set up by positioning the stop bar so that the V-bracket is supporting the neck of the case. Loosen the two screws of the V-bracket, so that it may be adjusted up and down. Adjust the V-bracket so the case is held level/parallel to the base. Tighten the two screws. Place the ball point of the indicator so it is touching the case about 1/8" from the shoulder. Rotate the case as in Accuracy Check 1. If variation of greater than .0015" to .002" is registered, you will want to look for ways to make the cases more consistent.

PHOTO 1

PHOTO 2



CRITICAL ACCURACY CHECK 3 — BULLET AND CARTRIDGE RUNOUT OF LOADED ROUNDS

Bullets will not leave a rifle barrel at a uniform angle unless they are started uniformly. The Forster Cartridge Inspector will give a reading of how closely the axis of the bullet corresponds with the axis of the cartridge case. The Inspector is unique in that it supports the work in a manner which checks bullet and case alignment in relation to the centerline (axis) of the cartridge. Ammunition with approximately the same axis may be selected and used for precision shooting. A spring-loaded plunger holds the cartridge against the stop bar while the case and the bullet are supported in V-blocks. Rotating the cartridge with your fingers transfers the degree of misalignment to the indicator. The sensitive dial indicator is graduated in thousandth-of-an-inch increments, but may easily be read in one-half-thousandths.

To check the concentricity of a completed cartridge round, set the Inspector up as shown in Photo 2 above. For most accurate readings, it is best to support the case just in front of the rim. See Figure A on Page 1 for proper contact points of support. Adjust the (bullet end) V-bracket so that the cartridge is level. Adjust the indicator so that it just touches the bullet about 1/8" from the case mouth. "Zero out" the dial if you so desire. Rotate the case while pressing downward with a continual, even pressure.

Our goal is runout of .000" to .002". Concentricity of .002" to .004" is adequate for some varmint and long-range shooting. If you detect bullet runout of more than .004", you should determine the cause. First, check the case neck walls for consistency and the possible need to outside neck turn. **Maximum overall cartridge length that may be inspected in this tool is 3.500" inches.**

Thank you for purchasing a Forster Precision Product. Please wear safety glasses.

Forster Catalogs are available upon request.

010482-005 Rev. 4