

---

# FORSTER PRODUCTS

---

310 E. LANARK AVE, LANARK, IL 61046    [www.forsterproducts.com](http://www.forsterproducts.com)    PHONE (815) 493-6360    FAX (815) 493-2371

---

## UNIVERSAL SIGHT MOUNTING FIXTURE INSTRUCTIONS



### INSTRUCTIONS FOR USE

This Fixture was especially designed for accurately drilling and tapping rifle actions and barrels for top mounts and target scope blocks, receiver sights, ramp sights, and beads on single barrel shotguns as well as side mounts whenever the mounting holes are in line with the centerline of the barrel. The V-blocks align the gun by the barrel. Even if the action is not exactly in line with the barrel, the Fixture automatically corrects this error and drills the holes true with the barrel.

The gun to be drilled and tapped should be removed from the stock. It is usually not necessary to remove the trigger mechanism on bolt actions. The Savage 99 requires only the removal of the forearm. The Remington 760 requires the removal of the slide and slide bolt, as well as the bolt mechanism. The barrel can then be held to the action with a standard 3/8" x 24 hex nut. Tubular magazine rifles must have the magazine removed before the drilling operation. The barrel is then laid in the V-blocks, the action over the end of the Fixture having the clearance slot. Whenever possible, the barrel to be drilled should be positioned so that the action is close to the rear V-block, with the cylindrical or straight portion of the barrel supported by the V-block.

Slide the over-arm in place over that portion of the action to be drilled and raise the rear V-block up to bring the action in contact with the correctly sized drill bushing. Next, measure the diameter of the barrel with a micrometer at the points of the contact at the front and rear V-blocks. As most barrels are tapered, it will be necessary to raise the front V-block. To arrive at the exact difference in height, subtract the small diameter from the larger diameter, multiply this value by .707, and raise the front V-block that much higher than the rear V-block. This can be done satisfactorily by measuring with a machinist's rule or, if extreme accuracy is desired, by means of a feeler gauge, between the top of the machined boss and the bottom of the V-block.

Next, clamp the barrel lightly, using the aluminum pads under the clamp screws to avoid marring the barrel. On the bolt actions, raise the flat-top support pad into firm contact with the flat bottom of the action. This squares up the action and acts as a support during the drilling operation. The clamp on top of the leveling block is used to hold the action when it is desirable to remove the clamp from the rear V-block, so that the over-arm may be moved over any part of the action. Now, tighten the clamps. Actions that have no flat bottom surface can be lined up by means of a square from either the top of the over-arm or any other machined surface on the Fixture. The gun also can be lined up by use of a level, but in this case be sure the Fixture is level before lining up the gun.

One method used by many gunsmiths to locate mounts is to place the mount on the action or barrel in the desired position and mark the forward hole on the gun with a scribe or pencil. Next, with the locator pin, point down in the front hole of the over-arm, slide it over the gun so the point lines up with the mark and lock in place. Drill and tap this hole. Now, screw the mount to the gun with one screw. Loosen the over-arm and, with the tapered point of the locator pin, locate the over-arm over the second hole in the mount and lock in place. Lock the spacer block against the over-arm. The over-arm then can be moved out of the way, the mount removed and the over-arm re-set against the spacer block. The second hole is then drilled and tapped. Other holes in the mount can be located and drilled in the same way. Do not drill the holes with the mount in place, as this may prevent drilling the holes on the true center of the action.

When drilling for receiver sights, line up the barrel in the V-blocks in the usual way, but turn the action sideways and square it up by means of a small square laid on top of the over-arm. Locate the first hole and proceed as outlined above. The same procedure is followed when mounting side mounts, but holds true only if all holes are in line with the center line of the barrel.

If the desired holes are not on the center line of the barrel, the Fixture still can be used to hold the gun squarely and steadily in the drill press. In this case, the over-arm is not used.

When drilling and tapping for a ramp sight, the gun is turned around, the muzzle end being at the notched end of the Fixture. The V-blocks in this case are raised high enough so the drill bushings will contact the barrel. Allowance must be made for the taper in the barrel as previously explained. In this case, it will be necessary to square up the gun with a level. Shotgun beads are mounted by following the same procedure.

Go easy at first and double-check your setups to be sure that you are drilling the holes exactly where you want them. Also, make sure that the V-blocks line up squarely by tightening the screws gently at first so that the flat of the screw squarely contacts the flat of the shaft. A twisted V-block will throw you off because of the taper in the barrel, and especially so if the barrel is supported at a point where the taper is abrupt.

**Extreme care should be used to prevent chips from getting between the finished surfaces of the over-arm and the body of the fixture when the over-arm is moved. This is equally true of the spacer block. If the chips are allowed to lodge between the two finished surfaces, they will impair the inherent accuracy of the fixture. Brush away all chips with a small, dry brush before loosening the over-arm and spacer block. Do not use too much force when tightening the screws holding the over-arm and spacer block.**

Unless otherwise ordered, drill and tap bushings are furnished for 6-48 thread. Drill and tap bushings can also be supplied in 8-40, 10-32, and 3-56 thread sizes.

**Thank you for purchasing a Forster Precision Product. Please wear safety glasses.**

**Forster Catalogs are available upon request.**

# UNIVERSAL SIGHT MOUNTING FIXTURE COMPONENT PARTS LIST

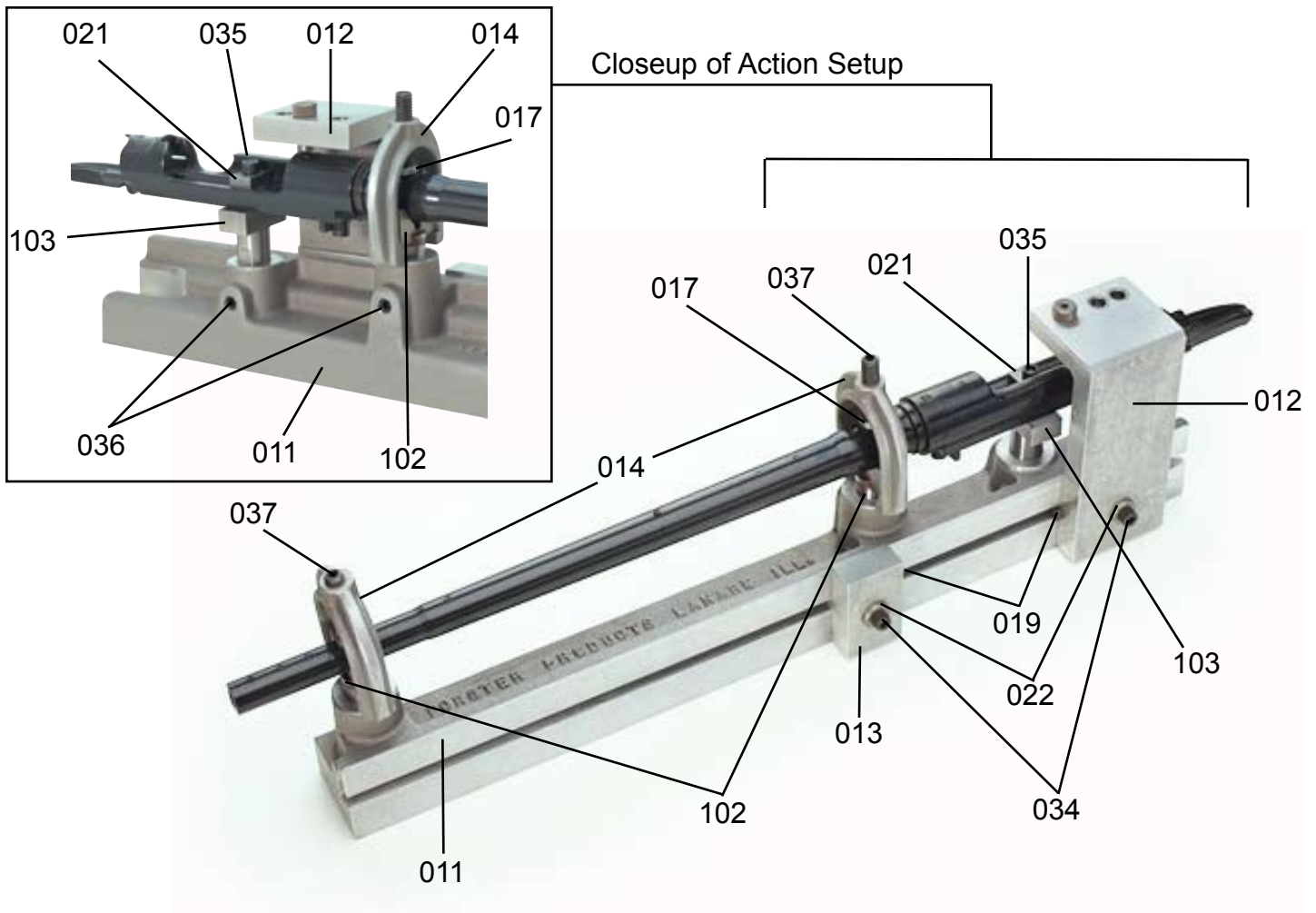

- UF1000.....COMPLETE UNIVERSAL SIGHT MOUNTING FIXTURE TOOL
- UF1000-011.....BASE CASTING (machined)
- UF1000-012.....OVERARM CASTING (machined)
- UF1000-013.....STOP BLOCK
- UF1000-014.....C-CLAMP CASTING
- (NOT SHOWN) UF1000-015.....LOCATING PIN (center)
- UF1000-017.....ALUMINUM PAD (2)
- UF1000-019.....STOP SCREW FOR OVERARM & STOP BLOCK (2)
- (NOT SHOWN) UF1000-020.....T-SLOT NUT FOR OVERARM AND STOP BLOCK (2)
- UF1000-021.....SUPPORT PAD CLAMP
- UF1000-022.....WASHER FOR OVERARM AND STOP BLOCK(2)
- UF1000-034.....T-SLOT SCREW FOR OVERARM AND STOP BLOCK (2)
- UF1000-035.....SCREW FOR SUPPORT PAD SHAFT/CLAMP ASSEMBLY
- UF1000-036.....3/8"-16 SCREW FOR 2 VBLOCKS & SUPPORT PAD (3)
- UF1000-037.....SCREW FOR BARREL "C" CLAMPS
- UF1000-100.....STOP BLOCK ASSEMBLY (P/N'S 13, 20, 22, 34)
- UF1000-102.....V BLOCK (assembled) (2)
- UF1000-103.....SUPPORT PAD (assembled)
  
- SHORTARM-HEXKEY3/16.....3/16 HEX WRENCH