

FORSTER PRODUCTS

310 E. LANARK AVENUE, LANARK, ILLINOIS 61046 PHONE: 815-493-6360 FAX: 815-493-2371 www.forsterproducts.com

User Instructions for 50 BMG Case Trimmers

1.0 GENERAL INFORMATION

Brass cases stretch after repeated firings. It becomes necessary to trim them to consistent length for proper chambering and for improved accuracy

The 50 BMG Case Trimmer is a fine, miniature lathe. The staggered tooth, high alloy steel cutter shaft provides fast, smooth, chatterless cutting. A #510 Pilot is included; however, variations in case brass thickness may also require a #505 Pilot (not included).

2.0 SAFETY INFORMATION

- Always wear safety glasses.

3.0 PREPARATION

3.1 Case Trimmer Final Assembly (See Fig. 1)

The Case Trimmer is partially assembled at the factory in order to fit snugly in the package. To finish the assembly, do the following (see Figs 1 and 2):

- Collet Assembly:
 1. Using a slotted screwdriver, remove the slotted screw from the base which holds the Collet Assembly to the base. Turn the Collet Assembly around so that the opening is facing the cutter shaft.

2. Refasten the Collet Assembly using the same hole and screw.

NOTICE

There is $\frac{1}{2}$ " of adjustment built into the Case Trimmer, allowing its capacity to be widened. To adjust, use the outer set of holes on the Collet Housing and Bearing when mounting them to the Base (see Fig. 2).

- Crank Handle and Stop Collar assembly:
 1. Unscrew the Crank Handle from the Cutter Shaft.
 2. Turn the Crank Handle around.
 3. Slip the Stop Collar over the Cutter Shaft
 4. Screw the Crank Handle on to the Cutter Shaft.

3.2 General Preparation

- Using the included mounting screws, securely fasten the Case Trimmer to a board (for easy set-up, mounting in a vise and storage) or to a bench. This will ensure both hands are free for the trimming operation.
- Have handy the following items:
 - Reliable manual to consult for correct case lengths.
 - Caliper for checking case lengths.
 - Light oil.
 - Grease.

Figure 1. Case Trimmer Assembly

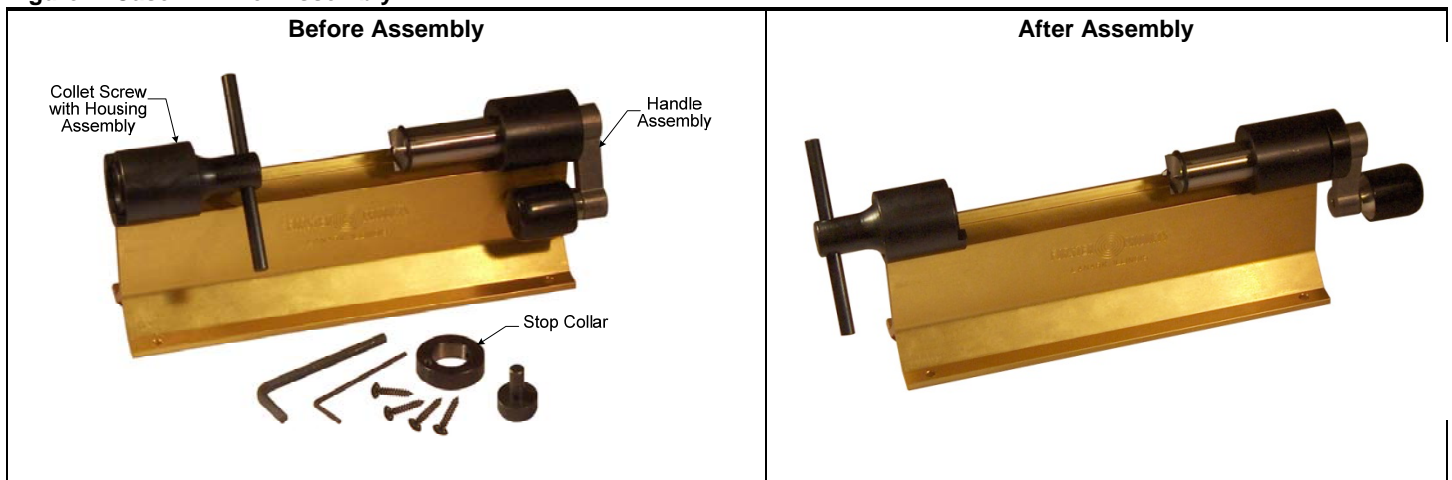
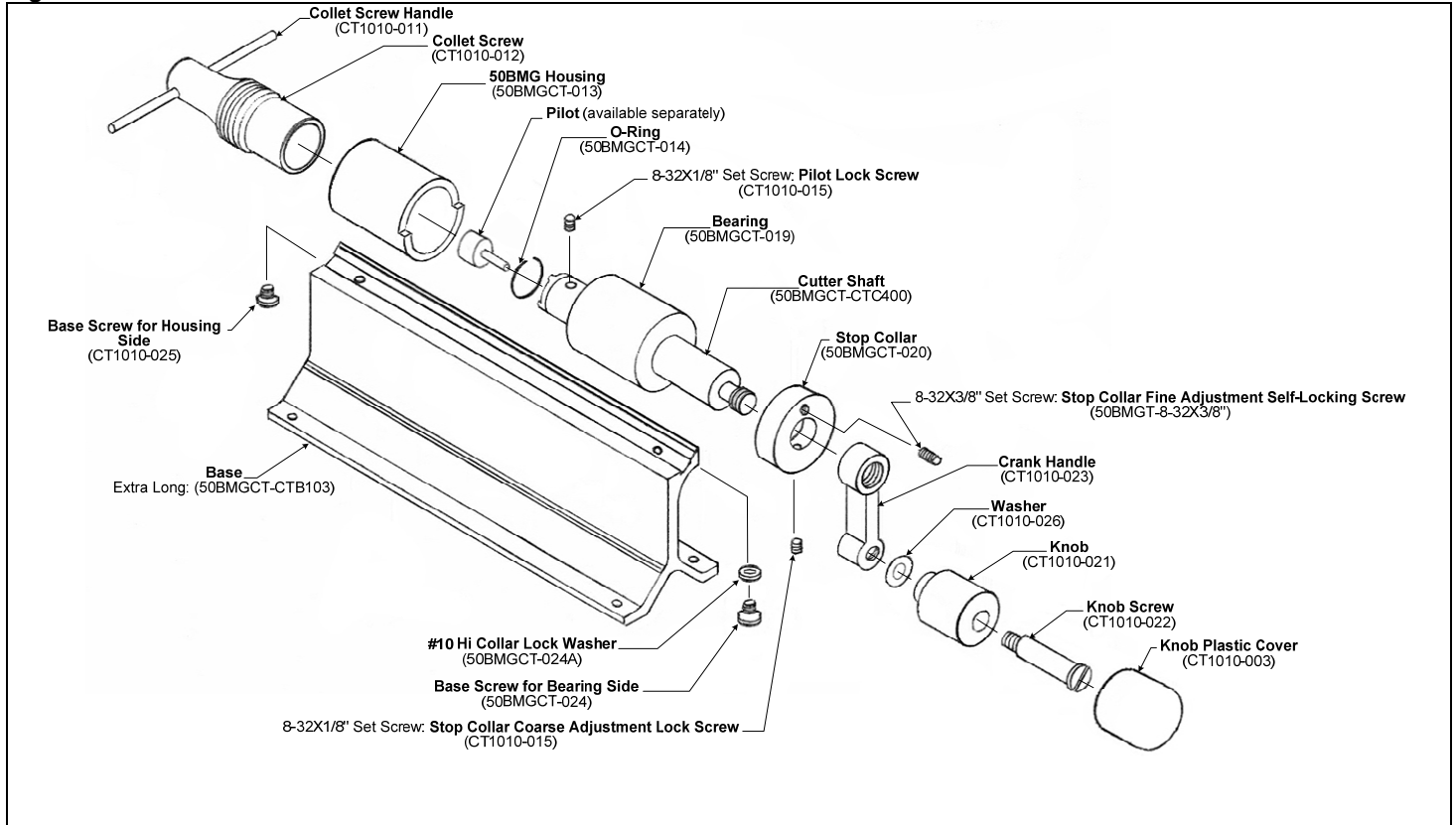

Figure 2. 50 BMG Case Trimmer Nomenclature



4.0 PROCEDURE

4.1 Assemble Pilot in Case Trimmer

1. Insert the Pilot into the Cutter Shaft.
2. Press the Pilot firmly against the cutter teeth and lock it in place by tightening the Pilot Lock Screw with the provided 5/64" allen wrench.

4.2 Insert Case and Adjust for Length

1. With tension released, insert the base of the case to be trimmed into the rim-holding device of the 50MBG Housing.
2. Move the Pilot into the neck of the case. With one hand on the Crank Handle, push the base of the case against the bottom of the 50MBG Housing. Ensure the base of the case is held firmly against the bottom of the 50MBG Housing and the Pilot is supporting the inside case neck, then tighten the Collet Screw with the other hand (see Fig. 3).
3. Ensure the cutter teeth are in contact with the case neck, then tighten the Stop Collar Coarse Adjustment Lock Screw.

Figure 3. Case Trimmer with Case Inserted



4.3 Make Trial Cut to Check Case Length

1. Turn the Crank handle to make a trial cut.
2. Remove the case and use a caliper to check its length.
3. Consult a reliable manual for correct case length.

4.4 Make Adjustments for Case Length and Set Stop Collar

1. Coarse adjustments: Move the Stop Collar along the Cutter Shaft to the desired location and tighten in place using the Stop Collar Coarse Adjustment Lock Screw.
2. Fine adjustments: Turn the Stop Collar Fine Adjustment Self-Locking Screw the desired amount (one complete turn equals .032" in case length):
 - A clockwise turn increases case length.
 - A counterclockwise turn decreases case length.
3. Make a final trial cut and check case length. Re-adjust, if necessary.

4.5 Trim Batch of Cases

1. The Case Trimmer is now set up to trim a batch of cases to the exact same length.
2. Occasionally lubricate the Cutter Shaft to Bearing surface with a drop of light oil when trimming.
3. Label and save a master setup case that is trimmed to the correct length. This will save setup time in future trimming operations.

5.0 AFTER USE

1. Store the Case Trimmer in a cool, dry location.

6.0 FORSTER CASE TRIMMER ACCESSORY

The **Forster Case Trimmer Power Adapter (PA1000)** allows the case trimmer to be powered by your electric screwdriver or power drill.

7.0 ORDERING INFORMATION

Table 1. 50 BMG Pilots

Order Number	Description
CT1510	510 Pilot
CT1505	505 Pilot

Table 2. 50 BMG Replacement Parts (See Fig. 2)

Order Number	Description
CT1010-011/ CT1010-012	Collet Screw Handle and Collet Screw
50BMGCT-013	50 BMG Housing
50BMGCT-014	O-Ring
50BMGCT-019	Bearing
50BMGCT-020	Stop Collar with Two Screws (CT1010-015, 50BMGCT-8-32X3/8")
CT1010-015	8-32x1/8" Set Screw (pilot lock and stop collar coarse adjustment lock)
50BMGCT-8-32X3/8"	8-32x3/8" Set Screw (stop collar fine adjustment self-locking)
CT1010-021	Knob
CT1010-003	Knob Plastic Cover
CT1010-022	Knob Screw
CT1010-023	Crank Handle
50BMGCT-024	Base Screw for Bearing Side (7/16" cap screw)
CT1010-025	Base Screw for Housing Side

Table 3. 50 BMG Complete Product

Order Number	Description
50BMGCT	50 BMG Case Trimmer (includes 510 pilot)

WARRANTY

All Forster Products are warranted against defects in materials and workmanship for the life of the product. Parts which, by nature of their function, are subject to normal wear (such as springs, pins, etc.) and parts which have been altered, abused or neglected, are excluded from the warranty. If the product is deemed defective by workmanship or materials, it will be repaired, reconditioned or replaced (at Forster's option). This warranty supersedes all other warranties for Forster Products whether written or oral.

www.forsterproducts.com

50BMGCT-002 Issue 2, February 2009