

FORSTER PRODUCTS

310 E. LANARK AVENUE, LANARK, ILLINOIS 61046 PHONE: 815-493-6360 FAX: 815-493-2371 www.forsterproducts.com

User Instructions for the Universal Bullet Puller

Issue 4

1.0 GENERAL INFORMATION

NOTICE

The Universal Bullet Puller (see Fig. 1) works with the **Forster Products Co-Ax® Press** as well as with any standard loading press with a 7/8" x 14 thread, and bullets from .17 cal. to .458 cal.

There are many reasons why a bullet may need to be pulled from a cartridge:

- To remove a bullet in order to replace it with a different bullet.
- To remove a bullet from a seated cartridge in order to re-seat different bullets to save powder and primer.
- To remove a bullet to change powder type and/or amounts.
- To customize factory ammunition for a specific purpose.

The Universal Bullet Puller:

- Uses case-hardened, solid steel Collets (see Fig. 2). Collets are sold separately (see Table 2).
- Provides an internal sure grip which reduces damage to the bullet, allowing more parts to be salvaged and reused (see Fig 3).
- Requires a separate 9/16" wrench to turn the Collet Screw (UP1010-012).

Figure 1. Universal Bullet Puller

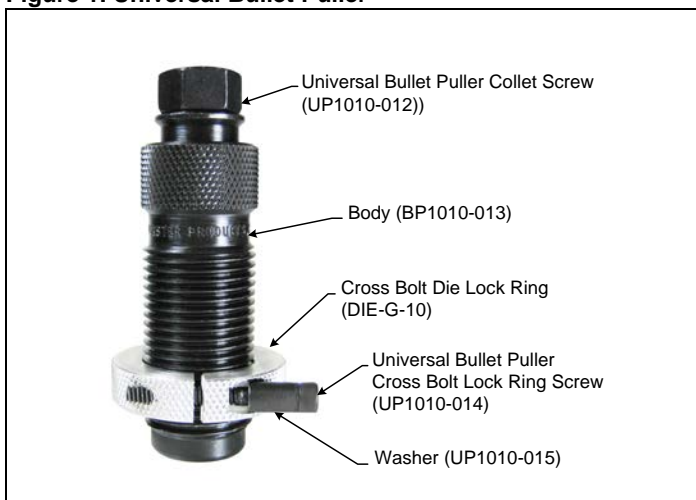

Figure 2. Collets



Figure 3. Cutaway of the Universal Bullet Puller (after bullet is pulled and before release)



2.0 SAFETY INFORMATION

- Always wear safety glasses.

3.0 PREPARATION

- Set up your reloading press.
- Have the following on hand:
 - 9/16" wrench
 - 7/64" Allen wrench
 - Grease

4.0 PROCEDURE

1. Select the proper collet for the bullet you wish to pull (see Table 2). Each collet is marked with the bullet diameter it will pull.
2. Apply a very small amount of grease to the tapered portion and base of the Collet.
3. Using the 9/16" wrench, turn the Universal Bullet Puller Collet Screw (UP1010-012) counter clockwise and remove it from the Body (BP1010-013).
4. Insert the Collet into the Body, tapered side down. The fit may be snug.
5. Replace the Collet Screw, and, using the 9/16" wrench, turn it clockwise to tighten.

CAUTION

COLLET DAMAGE

Ensure a bullet is engaged in the collet before tightening the collet screw.

Failure to comply with these instructions may result in product damage.

6. Using the 9/16" wrench, turn the Collet Screw clockwise to pre-tighten the Collet on the bullet you want to pull so that the inside diameter is slightly larger than the diameter of the bullet, but smaller than the cartridge case neck diameter. This ensures the cartridge case neck does not enter the Collet (see Fig. 4).

Figure 4. Correct Collet Location

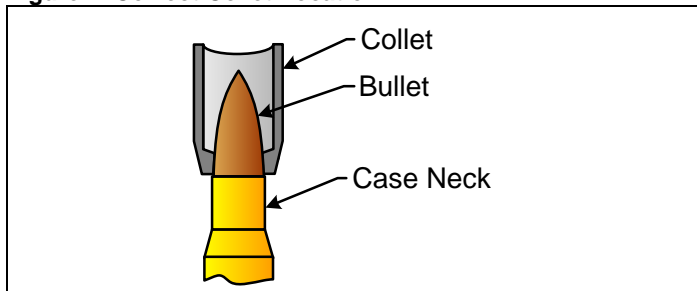

7. Tighten the Universal Bullet Puller Cross Bolt Lock Ring Screw (UP1010-014) so that the Cross Bolt Die Lock Ring (DIE-G-10) is secure and will not turn.
8. Mount the Bullet Puller into your reloading press:
 - **Co-Ax® Press:** ensure that the Universal Bullet Puller Cross Bolt Lock Ring Screw is in front of the press slot.
 - Other presses: screw the Universal Bullet Puller down through the press frame to a position where the bottom of the Collet will just contact the cartridge case neck.
9. Place the cartridge to be disassembled in the press shellholder.
10. Raise the shellholder by pulling the press handle.

CAUTION

COLLET DAMAGE

Ensure the cartridge case neck does not enter the Collet. Failure to comply with these instructions may result in product damage.

11. Using the 9/16" wrench, turn the Universal Collet Screw clockwise to tighten the Collet on the bullet.
12. Pull the case away from the bullet by reversing the loading press handle.
13. Using the 9/16" wrench, turn the Universal Collet Screw counterclockwise to release the bullet. If the bullet does not immediately release, use a hammer to gently tap the top of the Collet Screw to release the bullet.

5.0 AFTER USE

WARNING

PERSONAL INJURY

Ensure remaining powder and primer is properly reused or disposed. Failure to comply with these instructions could result in death or serious injury.

6.0 VIDEO

Go to our [Video Library](#) (see Video Library link under **RESOURCES** on our homepage) to see a video of the Universal Bullet Puller.

7.0 ORDERING INFORMATION

7.1 Universal Bullet Puller

Table 1. Complete Product

Order Number	Description
UP1010	Universal Bullet Puller (without collet)

7.2 Collets

Table 2. Collets

Order Number	Pulls Bullet Diameter	Order Number	Pulls Bullet Diameter
BP2017	.171"	BP2333	.333"
BP2204	.204"	BP2338	.338"
BP2224	.224"	BP2348	.348"
BP2243	.243"	BP2357 ¹	.357"
BP2257	.257"	BP2358 ²	.358"
BP2264	.264"	BP2375	.375"
BP2277	.277"	BP2400	.400"
BP2284	.284"	BP2410	.410"
BP2308	.308"	BP2432	.429" to .432"
BP2311	.311"	BP2452 ²	.452"
BP2323	.323"	BP2458	.458"

Notes:

1. Straight bored for rifle bullets.
2. Tapered and serrated ID for pistol bullets.

7.3 Standard Bullet Puller (related Forster Product)

The **Forster Standard Bullet Puller** fits any standard loading press with a 7/8" x 14 thread, and bullets from .17 cal. to .458 cal. It does not work with the **Forster Co-Ax® Press**. See our Web site for more information.

Table 3. Complete Product

Order Number	Description
BP1010	Standard Bullet Puller (without collet)

8.0 RESELLERS

We recommend using our Resellers when ordering our products. Their experience and knowledge will help you select the best products that meet your specific requirements. In addition, they usually offer the best prices and convenient delivery options. To find a Reseller, go to forsterproducts.com, then click on **Locate a Reseller**. If your Reseller cannot supply you, please contact Forster Products directly.

WARRANTY

All Forster Products are warranted against defects in materials and workmanship for the life of the product. Parts which, by nature of their function, are subject to normal wear (such as springs, pins, etc.) and parts which have been altered, abused or neglected, are excluded from the warranty. If the product is deemed defective by workmanship or materials, it will be repaired, reconditioned or replaced (at Forster's option). This warranty supersedes all other warranties for Forster Products whether written or oral.