

Troubleshooting Bullet Seating

Issue 3

CONTENTS

1.0 Background.....	1
2.0 Why Is There a “Ring” on My Bullet?	1
3.0 What Factors Might Have Caused the Marks?.....	1
4.0 Implications of Ringed Bullets	2
5.0 Troubleshooting Tips	2
6.0 If All Else Fails.....	2

1.0 Background

Bullet seating is the last and one of the most important steps in reloading. It is accomplished by pressing a bullet into a prepped case to the proper depth, using a caliber-specific Forster Products Seater Die:

- Bench Rest® Seater Die
- Ultra™ Micrometer Seater Die

Figure 1. Ultra Micrometer Seater Die Cutaway Diagram

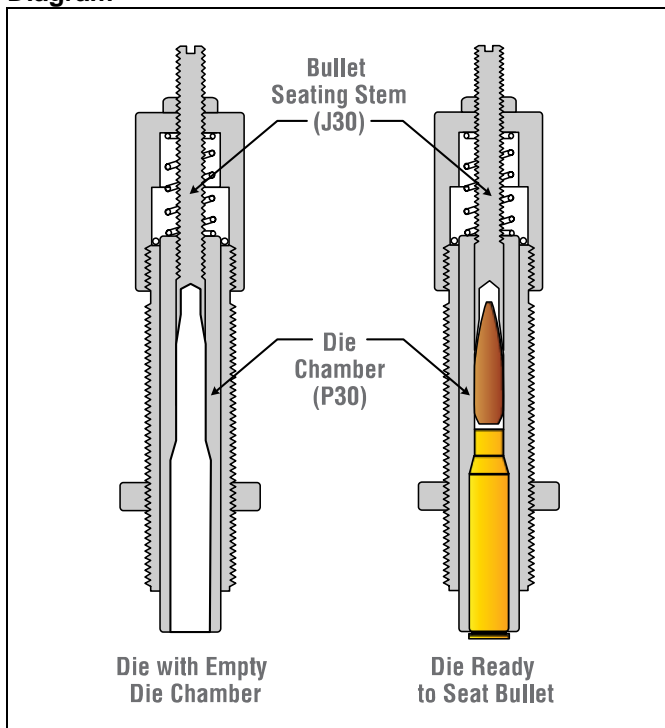

(that is, the weight). The good news is that, for many calibers, handloaders have a greater variety of projectiles to choose from.

The challenge for all reloading die manufacturers lies in creating a seating stem that will work with all of the different bullets on the market. Other die manufacturers even offer specific seating stems for specific bullets, or as a separate very low drag (VLD) stem.

The Forster Products approach has always been to try to accommodate all bullet types with the single stem that is installed in the Seater Die. Doing so requires constant re-engineering, which has become increasingly complex in recent years.

Our goal remains to produce the most accurate and reliable Seater Dies, with the least stress on the bullet possible.

2.0 Why Is There a “Ring” on My Bullet?

Forster Products answers many support questions about Seater Die usage, especially with regards to marks, or rings, left around seated bullets. There are a few possible causes, which can be addressed in most cases with improved reloading techniques and, where necessary, custom fitting of the stem.

3.0 What Factors Might Have Caused the Marks?

The bullet would have to be scarred where the stem contacts it at a point (see Fig. 2) with excessive force or where the bullet jacket does not have adequate material beneath the jacket.

The last couple decades have seen an incredible diversity in manufacturers’ bullet profiles and grains

In practice, every profile – and every grain of bullet within the same profile – will contact the stem differently.

Figure 2. Bullet Contact

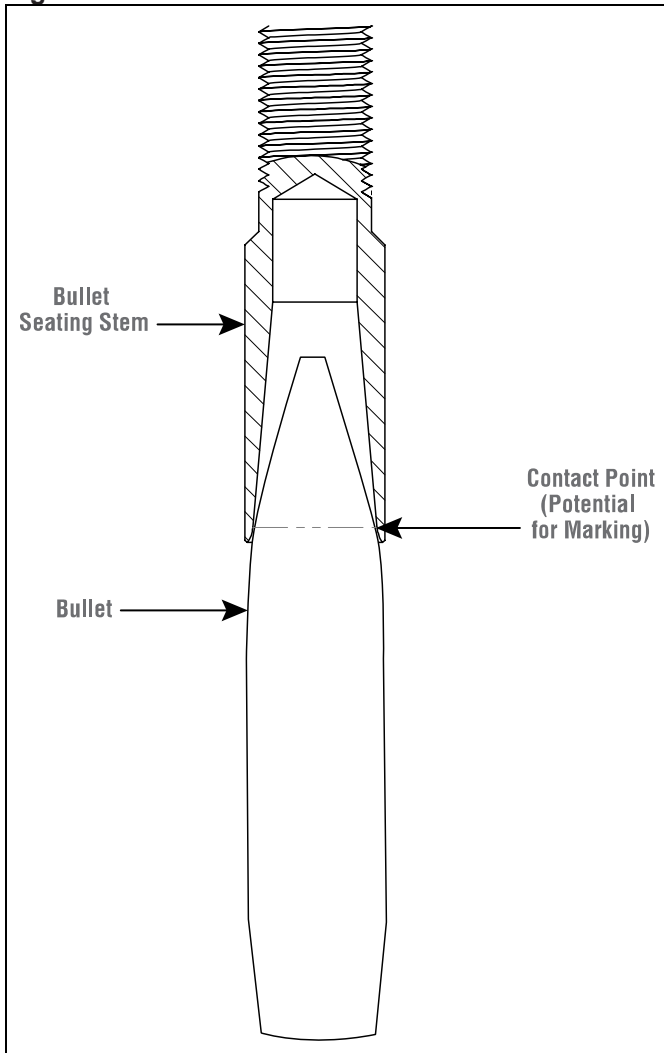

Additional complications, like crimping, are associated with pointed bullets or those with polymer tips, which are inherently softer. If the specific profile and grain you are shooting is contacting a limited portion of the seating stem at a soft part of the bullet, the risk of a ring's being formed during the seating process is elevated.

A further consideration, and a very common cause for ringed bullets, is simply improper case prep and powder handling. A ring can be a sign that it is taking an extra amount of pressure to seat the bullet – through neck tension, a compressed load, or burrs on the case mouth.

Having a new die leave a ring is far from expected but is increasing in likelihood due to the sheer number of bullet profiles/grains and the increased amount of unsupported (softer) material along the ogive.

4.0 Implications of Ringed Bullets

Most handloaders are understandably concerned about the impact on accuracy. When a ring is unavoidable, it is not necessarily going to alter the aerodynamics of the projectile. Sometimes, what is perceived as a ring is simply a mark from where the stem contacted a softer bullet and has not really changed its dimensions. In this case, the negative effects are minimal.

It would also depend on how far you are shooting as to the extent some deformation of the bullet would affect the overall group.

The short answer is: we never like to see a marked bullet, even if the only harm involves creating doubt about performance in the shooter's mind.

5.0 Troubleshooting Tips

Before assuming poor Seater Die performance, try these tips with cases that have been fired/uniformed through your rifle.

Symptom	Suggestion
Excessive force on press during bullet seating.	Measure the Expander Ball, when using a standard Sizing Die. (The Expander Ball should be 0.001" smaller than the bullet diameter.)
	Review which bushing is in place, when using a Bushing Bump Die.
	Avoid compressed loads in our chamber-style seaters, due to the tight tolerances in the bullet channel. The extra pressure could create binding in the Seater Die. The powder may fit better when charged with a Powder Funnel.
	Always chamfer/deburr the inner diameter of new brass; expand the case necks, if necessary.

6.0 If All Else Fails...

You may send Forster samples of the bullets you are using, along with prepped cases, to have a new Seating Stem polished to a custom fit. For pricing and more information, see **Custom Machining Services » Custom Polished Seating Stems.**

WARRANTY

All Forster Products are warranted against defects in materials and workmanship for the life of the product. Parts excluded from the warranty are those that, by nature of their function, are subject to normal wear (such as springs, pins, etc.) or that have been altered, abused, or neglected. If the product is deemed defective by workmanship or materials, it will be repaired, reconditioned or replaced (at Forster's option). This warranty supersedes all other warranties for Forster Products, whether written or oral.