

FORSTER PRODUCTS

310 SE LANARK AVENUE, LANARK, ILLINOIS 61046

PHONE: 815-493-6360

FAX: 815-493-2371

forsterproducts.com

User Instructions for the Co-Ax[®] Primer Seater

Issue 5

1.0 GENERAL INFORMATION

Co-Ax Primer Seater allows for fast, easy seating with a built-in primer flipper and loading tray. It seats primers flat and coaxially with the cartridge case for accurate alignment and penetration.

The unique design allows the operator to eliminate “slop” when working with a specific cartridge, translating into consistent seating, reliable ignition, and reduced misfires.

Case priming is a critical handloading operation because, in order for ammunition to perform efficiently, consistent powder ignition is mandatory. Crushed, broken-tipped, or protruding primers may be dangerous or cause variations in pressure. The case must be primed before adding new powder, so that your gun’s propellant powder is contained at the bottom of the case.

2.0 SAFETY INFORMATION

Please follow all pertinent safety procedures, such as wearing safety glasses and hearing protection, being in a well-lit and well-ventilated workspace, and having all reloading tools in top working condition and no flames, sparks, or static electricity nearby.

Always store primers in their original, compartmentalized packaging. Handle them with care and respect. Primers that touch each other are more dangerous than single primers. Refer to [Sporting Ammunition Primers](#) by SAAMI for further safety information.

The slot in the Feed Tube (011521-011XX) permits visual inspection to determine if any primers are reversed or not positioned square against the Primer Post (011521-019XX).

3.0 SETUP

You may use the Seater on a tabletop or fastened to a bench or board. Three mounting holes for a workbench are already machined into the base, or you may clamp it to a board.

Co-Ax Primer Seater comes with the Large Primer Seater Assembly (011521-101) installed. To replace it with the Small Primer Seater Assembly (011521-100), we recommend first locking the Shellholder Jaws (028271-016) to the center and moving the Assembly forward until it hits the back side of the Jaws:

1. Lock the three Jaws to the center (see Fig. 3a) by tightening with the 5/32 hex key provided.
2. Insert the Assembly into the back of the tool (see Fig. 3).
3. Move the Assembly forward so that the front end is even with the milled surface the Jaws travel in, so that the milled top surface is squared right and left with the front of the tool.
(It is important to align the Assembly correctly, since the primer Feed Tube rests on top of this flat surface, and all dimensions are zeroed to this tolerance.)
4. Lock the Set Screw (011521-020).

Slide the primer Tube into position, and compare your Primer Seater to Figures 3 and 3a to verify the correct positioning of the parts.

4.0 FILL PRIMERS IN FEED TUBE

Primers for U.S. cartridges come in two diameters — large (0.210”) and small (0.175”) — and two general types — rifle and pistol. Rifle primers have more rigid cups and a hotter flash than pistol primers.

The Primer Seater comes with two sizes of the Feed Tube (011521-011LG and 011521-011SM). To fill the Feed Tube with primers, you may use the Primer Seater tray or the Primer Tube Loader (sold separately), as described below.

4.0.1 FILL PRIMERS IN BUILT-IN TRAY

1. Empty the primers from their package into the Seater’s tray.
2. Place the Large or Small Tube into the built-in channel, as shown in Fig. 1. The anvil of the primer should face the slotted side of the Tube.
3. Fill the Tube by guiding the primers, anvil side-up, into the Tube.

Figure 1. Loading Primers into the Tube

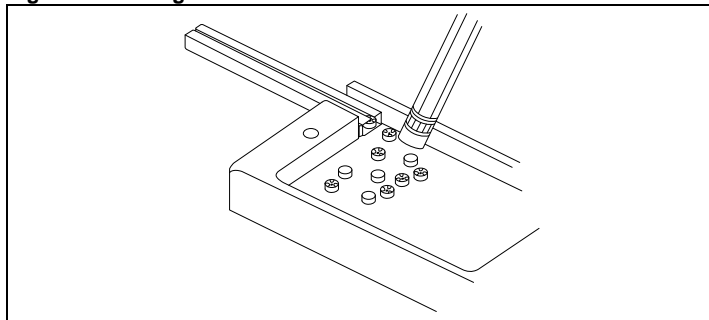

4.0.2 FILL PRIMERS IN PRIMER TUBE LOADER

1. Empty the primers from their package into the grooved tray of the Primer Tube Loader (011521-099) accessory.
2. Place the Feed Tube into the built-in channel, as shown in Fig. 2, slotted side up, inserting the end of the Tube that is not crimped.
3. Gently shake the tray from side to side as the primers quickly and automatically align themselves anvil side-up.
4. Tilt the Loader to guide the primers into the Tube.

Figure 2. Primer Tube Loader with Primers, Tube Attached

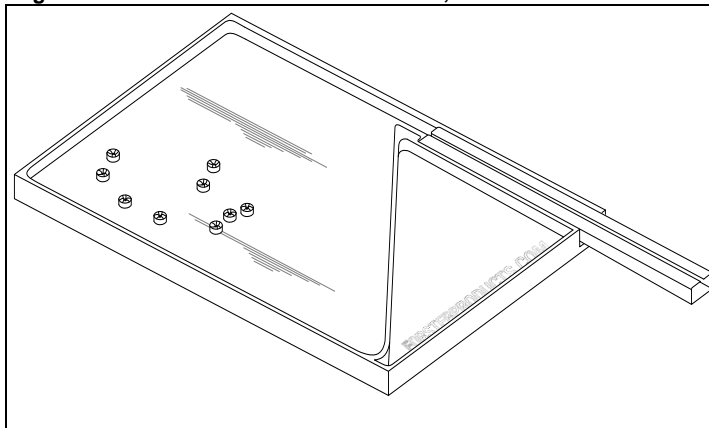

5.0 INSERT FEED TUBE INTO PRIMER SEATER

After filling, set the Tube with the primers aside until you are ready to insert them into the Primer Seater, as follows:

1. Turn the Tube over to guide the anvil side-down primers into the Tube.
2. Lift the Tube to allow the primers to slide to the top of the Tube.
3. Place a straightened paper clip through the hole in the Tube to hold the primers in place.

6.0 ALIGN THE JAWS FOR YOUR CASE

The provided Shellholder Jaws work on most modern boxer-primed rifle and pistol cartridges having a rim thickness of 0.045" to 0.072". The Jaws are easily identified and matched with a small dot on the small (0.054") end, as illustrated in Fig. 3a.

It is necessary to first determine which end of the Jaws you are going to use and set them accordingly. Most reloading manuals give complete cartridge dimensions as part of the loading data for that caliber.

1. Loosen the three Jaws slightly and center the primer pocket of your cartridge case on the primer seating Post (011521-019XX) by depressing the Handle slightly.
2. With slight pressure on the Handle, move each Jaw against the case rim and lightly tighten the Socket Head Cap Screws (SCR10-24X1/2SHDCP).
3. Rotate the case so that it moves freely; if it does not, loosen the Jaw at the point of friction, rotate the case, and finish tightening the three Socket Head Screws. (This method will build tolerance into the setting if the primer pockets are not perfectly concentric.)

4. Now, lock the Jaws and test a few cases to make sure the Jaws are properly located and locked in position to allow the primer seating Post to freely enter the primer pocket.

WARNING

PERSONAL INJURY

If you experience any misfeeding or malfunctioning with these processes – **STOP**. Remove all of the primers and go back to **6.0 ALIGN THE JAWS FOR YOUR CASE** and start with Step 1.

Failure to comply with these instructions could result in death or serious injury.

7.0 SEAT THE PRIMERS

Before seating, visually inspect the primers to make certain that the anvil of each primer is facing the slot in the Feed Tube.

1. Insert the Tube into the Seater and remove the paper clip.
2. Secure a case rim into the Jaws, with Co-Ax Primer Seater positioned so that the slot in the Tube is facing away from you.
3. Depress the Handle to seat the primer.

Seat primers with a slow, steady pressure to avoid breaking the primer pellets or setting off the primer.

CAUTION

- Avoid sudden or sharp blows when working with primers.
- To avoid the danger of forcing a live primer against a live seated primer, place all unprimed cases in a loading block with the rims up.
- Keep additional supplies of primers, powders, and flammables well away from your immediate work area and out of the reach of children.

Figure 3. Nomenclature

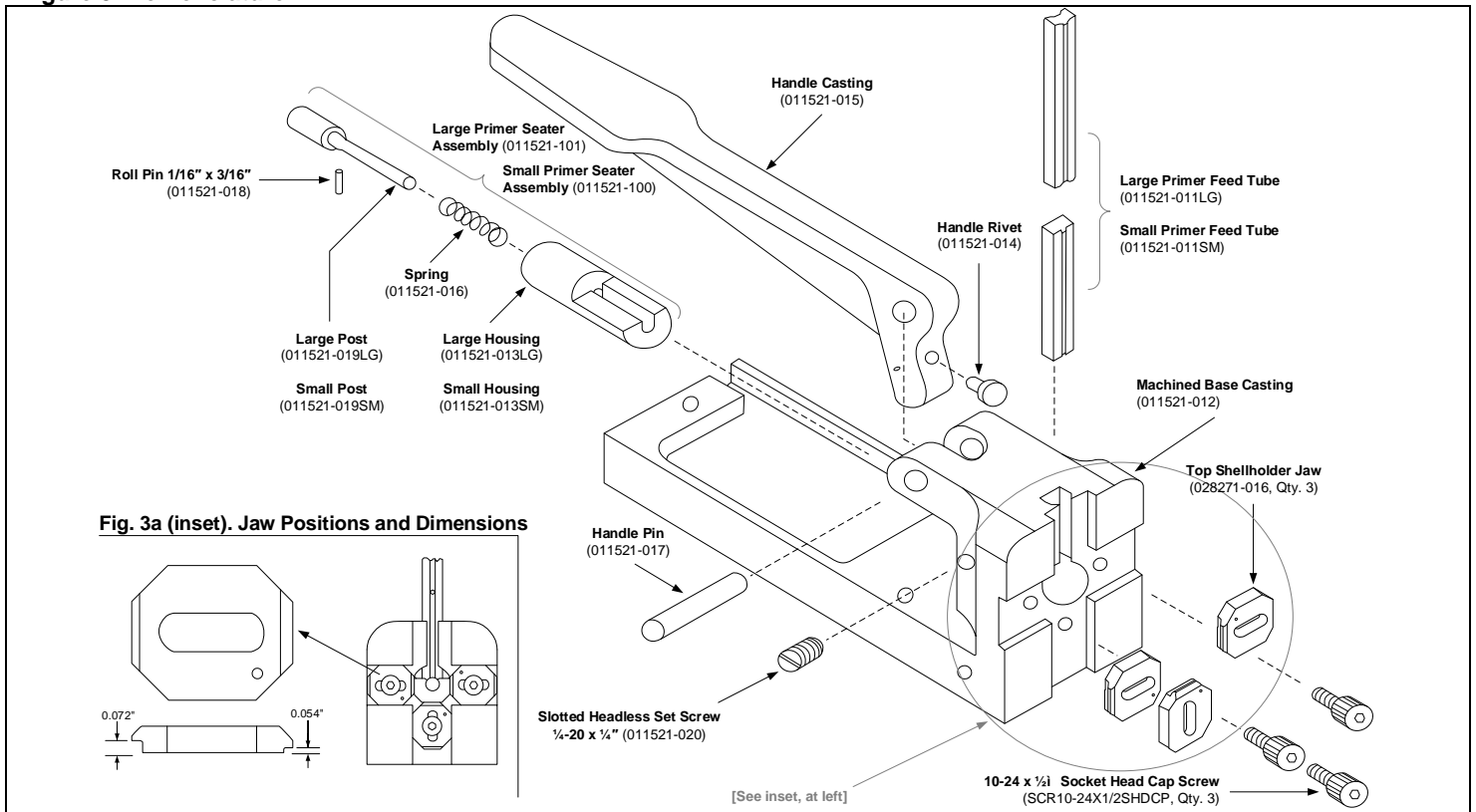

WARRANTY

All Forster Products are warranted against defects in materials and workmanship for the life of the product. Parts excluded from the warranty are those that, by nature of their function, are subject to normal wear (such as springs, pins, etc.) or that have been altered, abused, or neglected. If the product is deemed defective by workmanship or materials, it will be repaired, reconditioned or replaced (at Forster's option). This warranty supersedes all other warranties for Forster Products, whether written or oral.